



TRUCKCRAFT CORPORATION

5751 Molly Pitcher Hwy. S.
Chambersburg, Pa. 17201
Tel. 800.375.3867
Phone 717.375.2975
Fax 717.375.2975
www.truckcraft.com

"WHERE WORKMANSHIP IS EVERYTHING"

Preface

Read this manual carefully and follow its recommendations.

This manual contains information for the installation, operation, and maintenance of the TruckCraft TC-130 D-ICER unit. Proper care and operation of the spreader will assure years of dependable service, please have all operators carefully read this manual thoroughly before using equipment and keep for reference.

Your local TruckCraft Dealer will instruct you in its general operation. TruckCraft Corporation will be glad to answer any questions that may arise regarding the operation of your spreader.

Ordering Repair Parts

When service is necessary, your local TruckCraft dealer can provide the assistance you need. If you cannot locate a dealer near you, contact TruckCraft Corporation. Always obtain original TruckCraft replacement parts from your dealer, substitute items could affect the performance and warranty of the unit.

When ordering parts have unit model, serial number and description, or part number, of parts required. The serial number is located on the bottom right side of the spreader.

Method of shipping parts to be specified such as customer pickup, UPS, Common Carrier, Parcel Post or Air Freight. All orders to be confirmed in writing, or faxed, to insure proper understanding of request.

When possible having preventative maintenance parts on hand could save you valuable time.

Improvements and Changes

Because TruckCraft strives to continually improve our products, we reserve the right to make changes and improvements wherever practical, without obligation to make those same changes or improvements to the equipment already sold.

General Information

The TC-130 D-ICER is designed to fit our TC-120 Ultra Aluminum Pickup Dump Bed, and, with mounting adapters, will fit other models and brands of dump beds as well.

The TC-130 D-ICER consists of three independent components:

- Tailgate replacement assembly
- Spinner assembly
- Electrical control system

This unit is designed to handle all **free-flowing** ice control materials, including sand, salt, and abrasive up to $\frac{3}{4}$ " in diameter. It will not break up frozen lumps and cannot force material into the auger if the material is not free flowing. The maximum flow rate is 10,000 pounds per hour of material.



Figure 1 TC-130 D-ICER

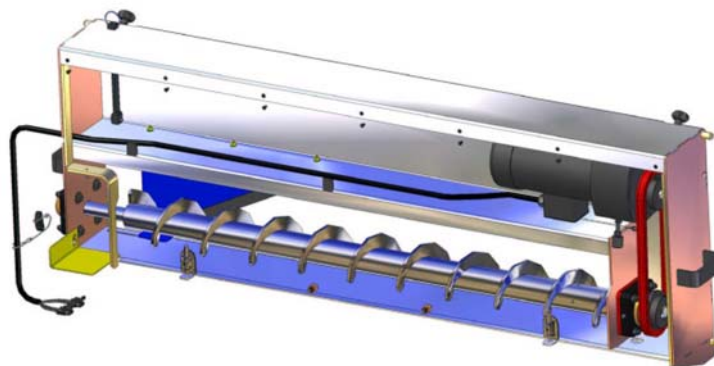

Figure 2 View with cover removed



"WHERE WORKMANSHIP IS EVERYTHING"

TRUCKCRAFT CORPORATION
5751 Molly Pitcher Hwy. S.
Chambersburg, Pa. 17201
Tel. 800.375.3867
Phone 717.375.2975
Fax 717.375.2975
www.truckcraft.com

Contents

Preface 1
Ordering Repair Parts..... 1
General Information..... 2
Contents 3
Operating Instructions 4
Maintenance: 7
Installation Instructions for TC-130 D-ICER 8
Installing the Tailgate Replacement Unit..... 8
(See Drawing D2-00820 and Parts List at end of manual)..... 8
Installing the Spinner Unit 8
(See Drawing D2-00882 and Parts List at end of manual)..... 8
Installing the Electronic Controls..... 9
(See Drawing #C2-02255 and Parts List at end of manual)..... 9

Operating Instructions



THIS SYMBOL IS USED THROUGHOUT THIS BOOK WHENEVER PERSONAL SAFETY IS INVOLVED. TAKE TIME TO READ AND FOLLOW THE INSTRUCTONS. BE CAREFUL!

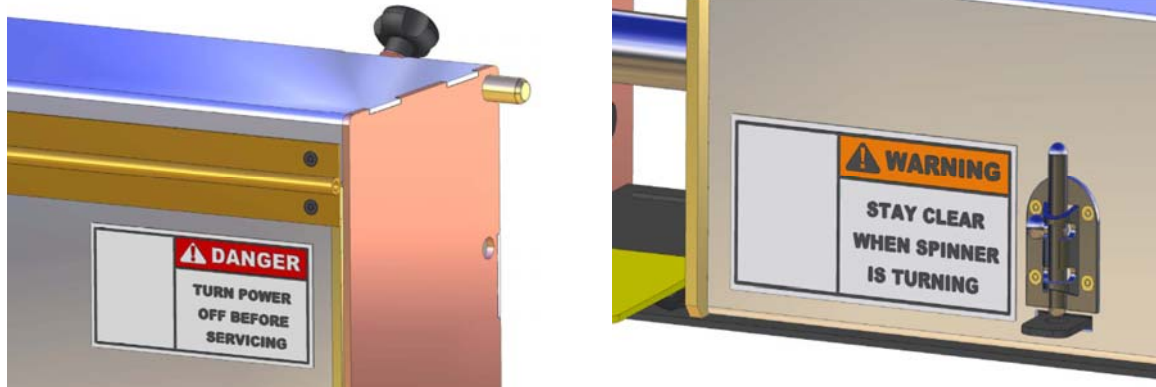

Figure 3



Observe the following safety procedures before and during use of spreader. Avoid possible injury and damage to equipment by following these rules and applying common sense.

Safety:

- **REVIEW** the operating instructions that were furnished with your dump body.
- **NEVER** exceed the rating of your truck, axles, or tires.
- **NEVER** exceed the manufacturers rating of the dump bed.
- **ALWAYS** watch for overhead wires and other height limitations when driving with bed lifted.
- **NEVER** drive with the dump bed raised any more than absolutely necessary.
- **NEVER** drive with the bed lifted when road surface is not level.
- **NEVER** allow frozen clumps to get into the auger.
- **NEVER** operate the auger with the cover open.

Operation:

Positioning the spinner

Raise the bed while observing the clearance between the spinner unit and the auger housing. With the spinner unit positioned approximately as shown on "Illustration A" Fig.4, load some deicing material in the bed for final adjustment of the spinner. Position the bed with the front bottom edge at eye level when sitting in the cab. This is the recommended operating position and the position to have the bed in when making final adjustments to the spinner location. With the bed raised to this elevation you can now run some material through the spinner and adjust the pattern to the position that you want it. Moving the spinner to the left moves the pattern clockwise and moving it to the right causes the pattern to move counterclockwise. The speed of the spinner changes the distance the material will be thrown and consequently the area to be covered.

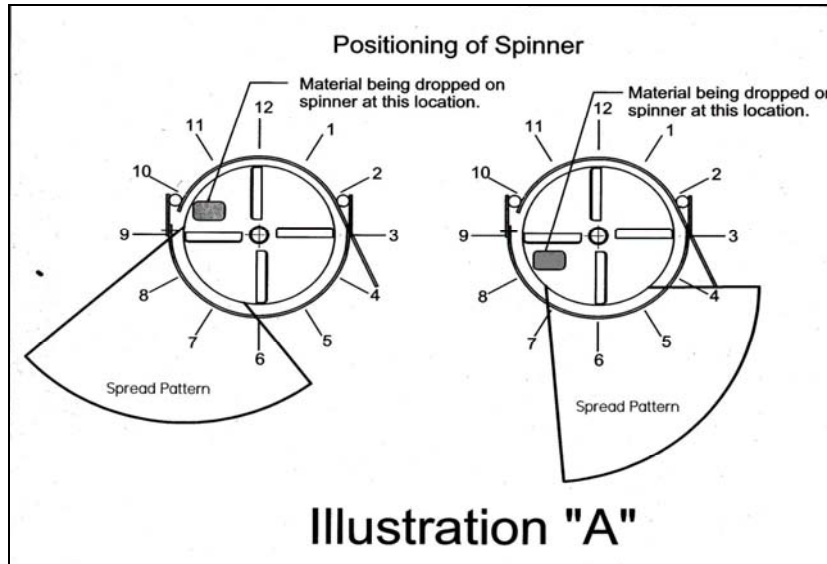

Figure 4

Baffle

In front of the auger on the drivers side is a bolt in baffle, Fig. 5. This baffle is used to prevent material from emptying from the bed when the bed is down and the auger is not running.

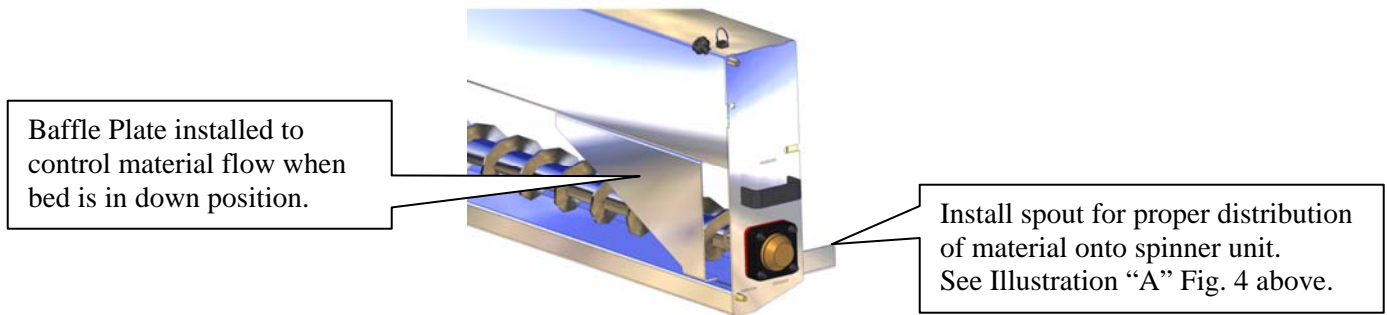

Figure 5

Spreading material

It is recommended that you not drive the truck with the bed raised any more than is necessary, and that you be constantly vigilant in watching for overhead obstructions and wires. When the auger empties the material that flows into it, stop and raise the bed to cause more material to flow into the auger. The speed of the auger controls the volume of material being spread while the speed of the spinner controls the area that is being covered.

The Electronic Control Unit (ECU) provides all controls for the D-ICER, Fig. 6. When preparing to spread material, first turn on the main "Power" using the button indicated. Second, turn both speed control knobs to zero. Third, engage the switch marked "Motors". Fourth, adjust the speed of the motors. If you are running the auger at less than full speed and you encounter an area that you want to apply material to at the full rate just engage the switch marked "Overdrive" for the time needed. This will run the auger motor at full speed and full power until you decided to switch back to the speed setting on the variable speed control. The "Overdrive" switch allows you to switch back and forth between the setting on the variable speed control and full speed without changing the variable speed setting. In situations where you need to stop both motors simultaneously and want to retain the variable speed settings, use the "Motors" switch. Always turn the motors off using the "Motors" switch prior to turning the power off at the "Power" switch. This will assure that the motors will not start running as soon as the power is turned on. If a jam occurs the "Jam" light on the ECU will light. When this occurs you should lower the bed and **turn the power off** at the ECU. Open the cover on the auger housing and clear the jam. A pipe wrench can be used to turn the auger in reverse direction if necessary. It is highly recommended that screened material be used to avoid clogging. The ECU and wiring circuits are protected as follows:

<u>Protection Device</u>	<u>Location</u>	<u>Circuits Protected</u>
10 Amp. fuse	Black box	Main power solenoid at battery circuit
120 Amp. fuse	Black box	Main power to ECU at battery
10 Amp. fuse	Back of ECU	Dump raise/lower Pump motor run
30 Amp. fuse	Back of ECU	Work light or other equipment



Figure 6

Maintenance:

Auger bearings

Once per season add a small amount of grease slowly to each bearing. Take care to not add the grease too fast or it will dislodge the end covers.

Roller Chain

Spray with WD40 periodically

Entire unit

At the end of the season do a thorough wash down and cleaning prior to storing the unit for the summer.

Installation Instructions for TC-130 D-ICER

Installing the Tailgate Replacement Unit

(See Drawing D2-00820 and Parts List at end of manual)

Replace the existing tailgate with the auger unit, Fig.7



Figure 7

Installing the Spinner Unit

(See Drawing D2-00882 and Parts List at end of manual)

Insert the spinner unit mounting bracket on to the 1" pin on the driver's side of the Auger Housing Assembly, Fig.8. Using the hose clamp provided, mount the bumper bracket to the bumper directly under the Spinner Assembly. Attach the turnbuckle and adjust the length to level the Spinner.



Figure 8

Installing the Electronic Controls

(See Drawing #C2-02255 and Parts List at end of manual)

- Step #1.** Find a suitable location for the Electronic Control Unit (ECU). A good location is over the transmission where the bracket can be bolted to the floor, Fig.9, or, to the underside of the dash.



Figure 9

- Step #2.** Install the engine compartment wiring harness. This harness includes a black box that contains a solenoid for turning the main power on and off to the ECU. The box also includes a 125 amp fuse for protection of the main power wire and a 10 amp fuse to protect the control circuit to the solenoid. The harness is installed with the black box located close to the battery. **Fig.10 Do not attach the wire lugs to the battery until all other wiring is installed.** Attach the wiring harness to existing wiring, brackets, or other non-moving parts in the engine compartment. **Do not attach or get the wiring harness near heat generating components.**

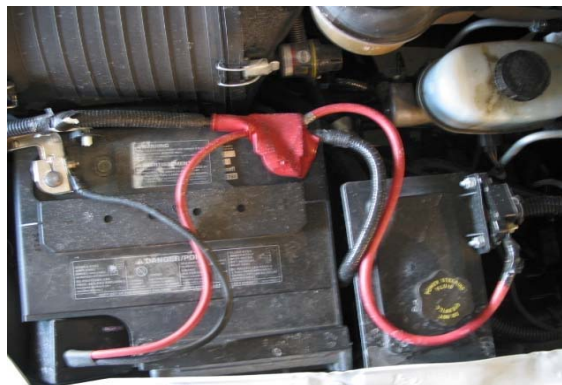

Figure 10

Find a location on the firewall to run the wiring through. An existing opening with a rubber grommet is preferred. Most trucks provide an opening for this purpose and locate it near the fuse box under the dash. Fig.11



Figure 11

Plug the large **red(+)** and **black(-)** power wires into the wires on the back of the ECU. Plug the small black wire from the black box into the small **black** wire on the ECU pigtail. Fig.12



Figure 12

Step #3. Install the rear wiring harness. At the rear of the truck on the drivers' side find a suitable location for the bracket and plugs that are at one end of the wiring harness. This location should be inside of the pickup box at the tailgate. The harness can be routed under the bed and up through the rear corner post, Fig.13, or along the underside of the bed box rail. The location should be accessible from the rear or side of the truck so that the power cords can easily be connected and disconnected.

Use the holes in the bracket to locate (2) 3/16" drilled holes for mounting the bracket to the truck. The bracket is stainless steel and does not need to be painted.



Figure 13

Run the wiring harness along the truck frame and into the cab. Assure that the wiring does not contact any sharp objects and that it is not located too near to any heat source. Plug the wires into the wires on the back of the ECU. Fig.14

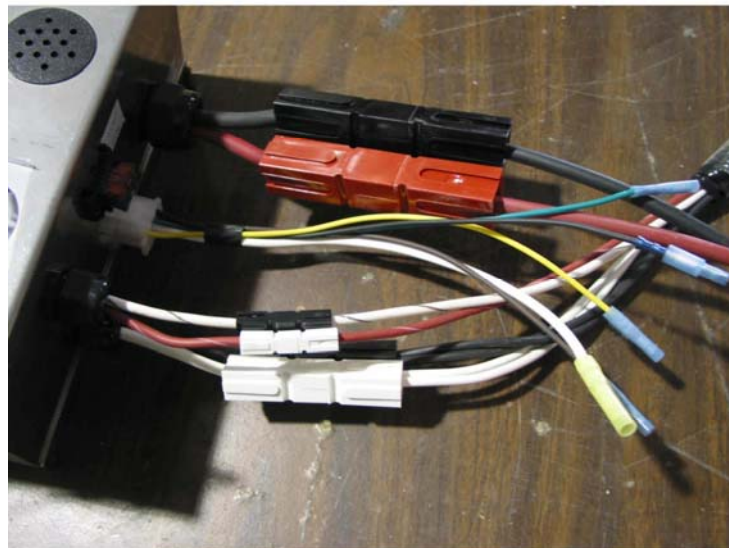

Figure 14

- Step #4.** Install the dump body raise and lower wire. The wire is a 3-conductor wire consisting of **green, yellow, & brown** wires. For pickup insert dumpers like the TruckCraft TC-100 and TC-120 the dump body is **power up, gravity down**, with only the **green** and **yellow** wires being used, Fig.14. For other dump bodies, which are **power up, power down**, all three wires are used.
- If the hydraulic power unit is a **power up, gravity down** unit, attach the **green** wire to the solenoid actuation terminal on the motor solenoid.
 - In the case of a **power up, power down** power unit, attach the **green** wire to the bed raise solenoid valve. The **brown** wire is attached to the solenoid actuation terminal on the motor solenoid.
 - With either type unit the **yellow** wire is attached to the bed lower solenoid valve. Run the wires into the cab of the truck and crimp the wires to the wires on the ECU of the matching color.
- Note: This circuit can be used in parallel with a separate dump body control circuit.

- Step #5.** The ECU is provided with a 30 amp. circuit for controlling a work light (lights) or other equipment. Fig.15 Make sure the light is attached to a proper ground such as the screws used to install the plug bracket. The dump body, auger housing and or the spinner **do not** provide an adequate ground. There are too many moving parts and in the case of the TC-120 it is isolated by phenolic bushings. Run the control wire into the cab and crimp it to the **white** wire on the ECU.

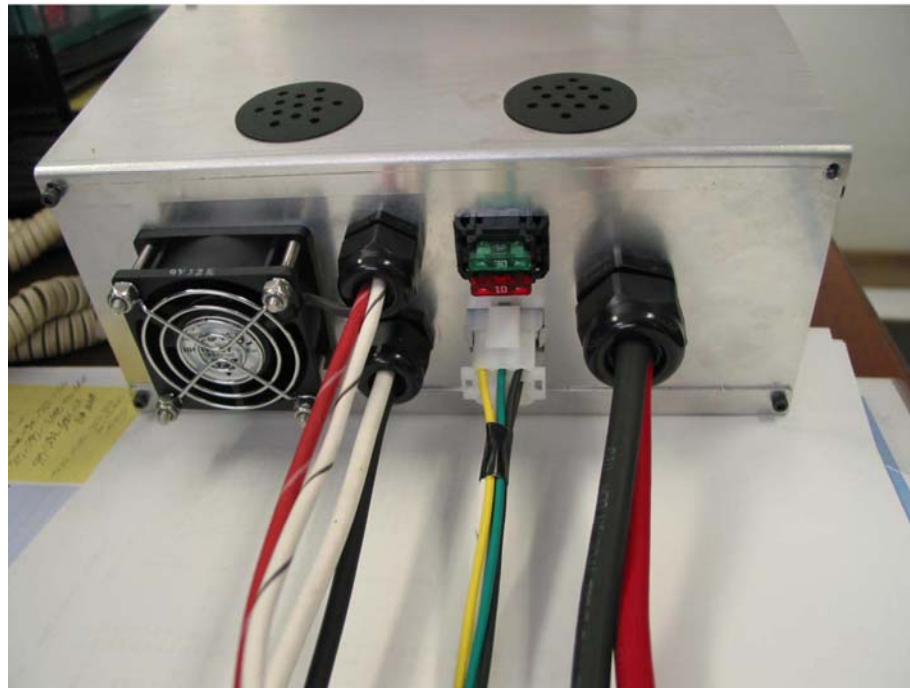

Figure 15

Step #6. With all of the switches on the ECU set to the off position, connect the positive and the negative wires to the battery. Plug the auger and spinner power cords into the receptacle plugs at the back of the truck.

Step #7. Make sure that no one is near the D-ICER prior to turning the power on and checking out all of the functions. Fig.16



Figure 16

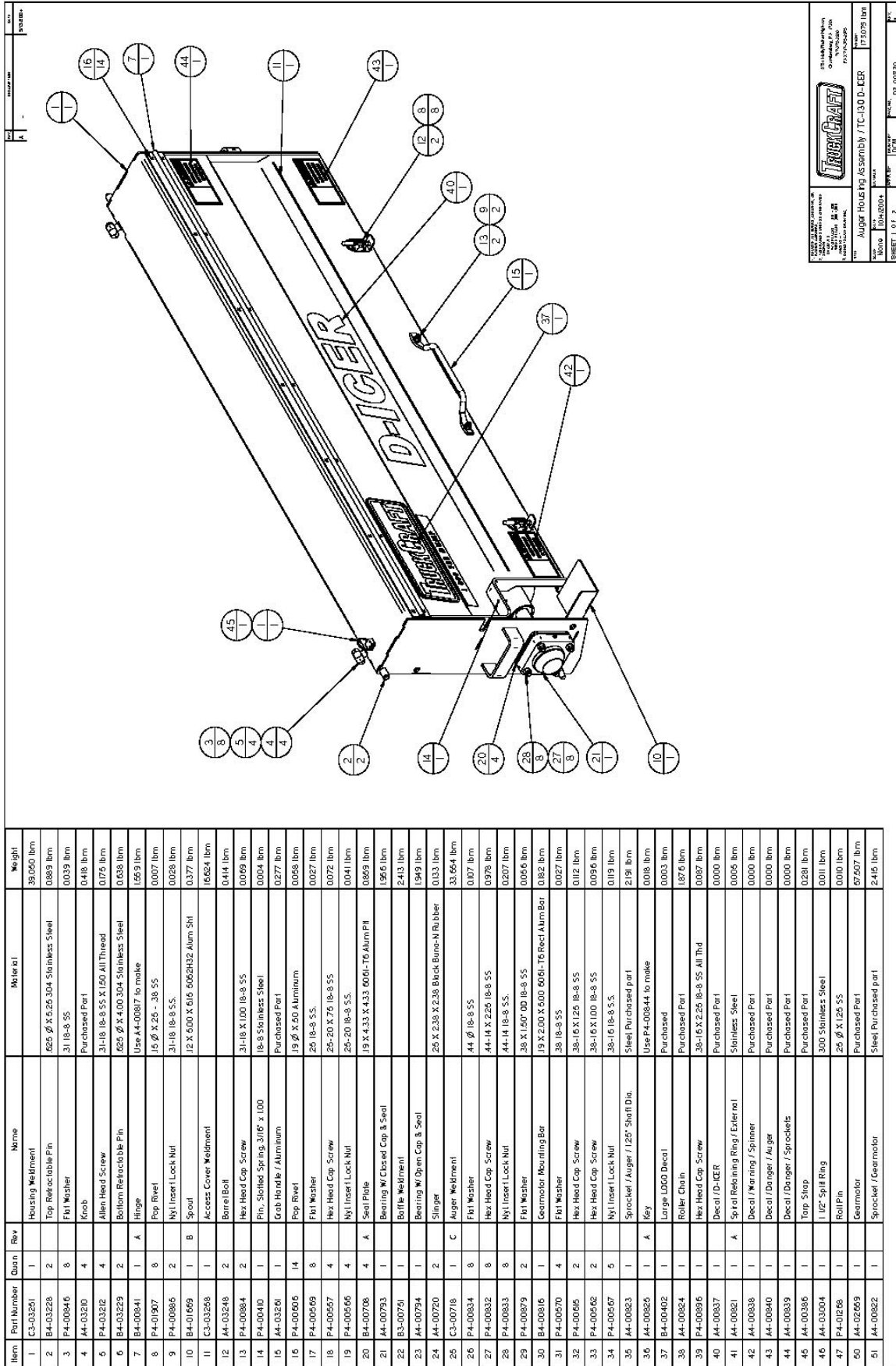

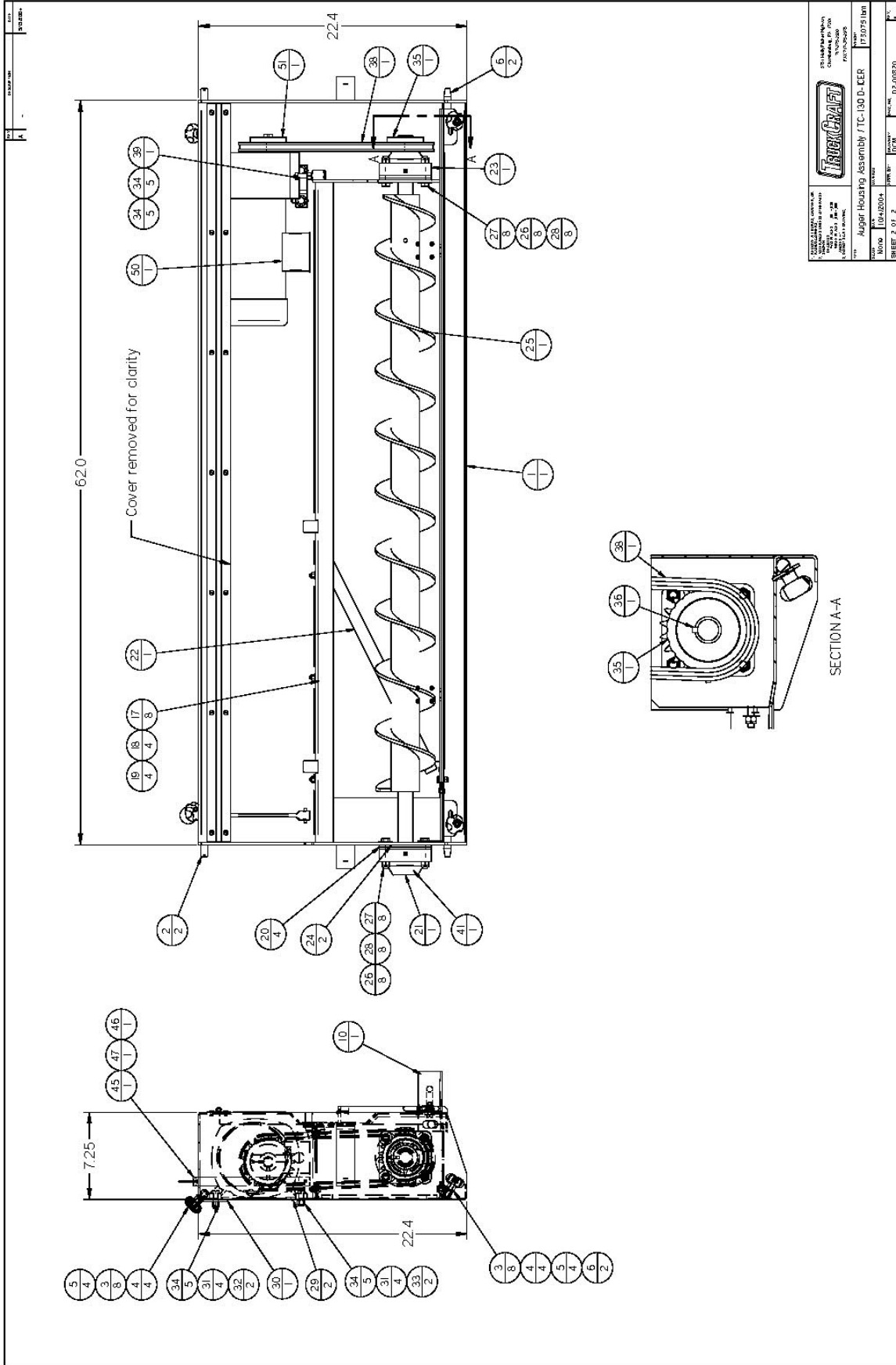

Item	Part Number	Quan	Rev	Name	Material
1	P4-00884	4		Hex Head Cap Screw	3/16 X 1.00 18-8 SS
2	P4-00845	8		Flat Washer	#10 18-8 SS
3	P4-00570	2		Flat Washer	3/8 18-8 SS
4	A4-01282	1		U Bolt	Purchased Part
5	P4-00837	8		Nyl. Insert Lock Nut - #10-32	18-8 S.S.
6	P4-00885	4		Nyl. Insert Lock Nut	3/16 18-8 S.S.
7	P4-00846	4		Flat Washer	3/16 18-8 S.S.
8	A4-00906	1		Spinner Assembly / 1/4Hp Motor	
9	B2-02529	1		Spinner Plate Assembly	
10	P4-00886	4		Pan Head Machine Screw	#10-32 X 1.00 Phillips 18-8 S.S.
11	P4-00567	2		Nyl. Insert Lock Nut	3/8-16 18-8 S.S.
12	A4-01464	1	A	Mounting Pin	1.000 X 4.00 304 SS Bar
13	A4-01440	2		Hairpin	Purchased Part
14	P4-01444	1		Flat Washer, Thick	63' 18-8 SS
15	P4-01279	1		Hex Head Cap Screw	63 - 11 X 1.25 316 SS All Thread
16	P4-01495	2		Cotter Pin	19 Ø X 1.50 18-8 SS
17	B2-03014	2		Cable Assembly	
18	P4-03670	1		Gasket - 5/8 x 24 1/2" cut length	Foam Gasket PSA / Purchased 2.5 Tolls
19	P4-00883	1		Cup Point Set Screw 2.5-20 x .38 lg	18-8 S5T
20	B3-01469	1		Bumper Rest Weldment	Purchased part 304 S5T
21	A4-01281	1		Hose Clamp 63"W x 6.13-9.13 Dia	
22	A4-00842	1		Turbo buckle	
23	P4-02785	1		Felt Washer 1/4"Thk x 3/4" Dx 1 1/4" O.D.	Purchased part, Felt washer
24	A4-01494	1		KEY .19 x .19 x 1.00 lg	Stainless Steel - make from P4-00860
25	A4-01494	1		Cap - 3/4"	PVC Cap 3/4" Sch 40
26	B3-00760	1		Spinner Caution Shield	
27	B3-03441	1	A	Spinner Mounting Tube Weldment	
28	C3-00774	1		Spinner Support Weldment	
29	B4-00761	1		Deflector	17 x 3.50 x 24.0" Black Polymer
30	A4-00889	4		Nylon Loop Clamp 1.0"	Purchased Part, Black Polymer
31	P4-00888	4		Pan Head Mach Screw #10-32x.63' Philips	#18-8 S.S.

SECTION A-A

Cord length 38" lg

TRUCKCRAFT

TRUCKCRAFT CORPORATION
 10000 W. 10TH AVENUE
 DENVER, CO 80231
 PHONE: 303.440.1000
 FAX: 303.440.1001
 WWW: WWW.TRUCKCRAFT.COM

SPINNER ASSEMBLY (DEALER / IN-HP MOTOR)
 Part # I6-01424 Rev. A
 Date: 1/27/2009
 Sheet 1 of 1
 Rev: 02-00882

Notes:
 1. Use locktite when assembling items 4 & 23.
 2. Use Anti-seize when assembling item #2 to item #1.

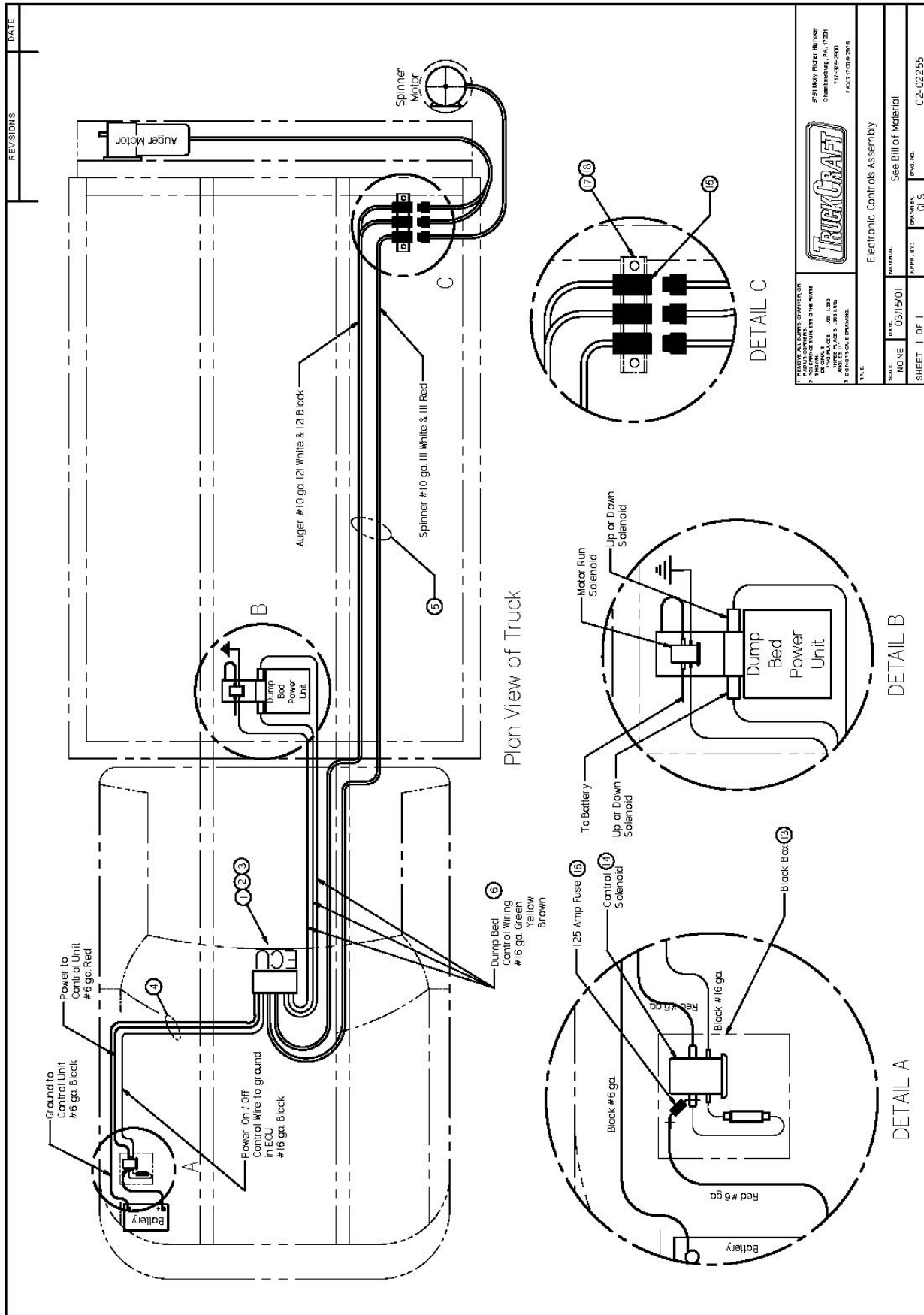

REVISIONS	DATE

675 NEW HAVEN HIGHWAY GREENWICH, PA, 17321 PHONE: 717-836-5000 FAX: 717-836-2819	
TITLE: Electronic Controls Assembly	
SCALE: NONE	MATERIAL: See Bill of Material
SHEET: 1 OF 1	DWG. NO.: C2-02255

Number: **C2-02255**  **TruckCraft Corporation** Date: 10/9/01 By: GLS
 Name: **Electronic Controls Assembly** Bill Of Material Sheet: 1 Of 1 Rev:

ITEM	PART NUMBER	QUAN.	REV.	NAME	DESCRIPTION
1	C4-02245	1		Electronic Control Unit	
2	P4-02406	2		Flat Washer	.25 X 1.25 18-8 S.S.
3	P4-02376	2		Hex Washer Head Thread-Form Zinc Plated Type B .25-14 X .75	
4	B2-02407	1		Wiring Harness / Engine Compt.	
5	B2-02531	1		Wiring Harness Assembly / Motors	
6	M4-02405	1		Parallel Bonded Cable	Green, Brown, Yellow X 20'-0" lg.
7					
8					
9					
10					
11					The Following List is ReplacemehParts
12					
13	A4-02396			Box Detail	
14	A4-02389			Solenoid	
15	A2-02410			Cavity Plug Assembly	
16	A4-02388			Fuse	125 Amp
17	A2-02533			Bracket Assembly	
18	P4-02376			Hex Washer Head Thread-Form Zinc Plated Type B .25-14 X .75	